

MIX-ON



| MODELLO | CAPACITÀ VASCA | MOTORE ELETTRICO | CAPACITÀ PRODUTTIVA |
|--------------------|----------------|------------------|---------------------|
| MIX-ON 159 | 15 mc | 1x90 kW | > 25 t/h |
| MIX-ON 189 | 18 mc | 1x90 kW | > 30 t/h |
| MIX-ON 2111 | 21 mc | 1x132 kW | > 40 t/h |
| MIX-ON 2411 | 24 mc | 1x132 kW | 50 t/h |

CARATTERISTICHE PRINCIPALI

N°01 albero miscelatore a fondo vasca con pale rinforzate

N°02 coclee superiori controrotanti di rinvio

Impianto pesa elettronica

Scarico anteriore destro con portina azionata idraulicamente

Segnale luminoso di indicazione apertura portina di scarico

MIX-ON

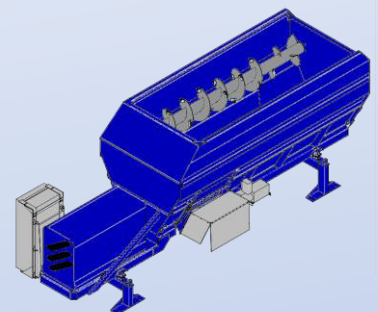
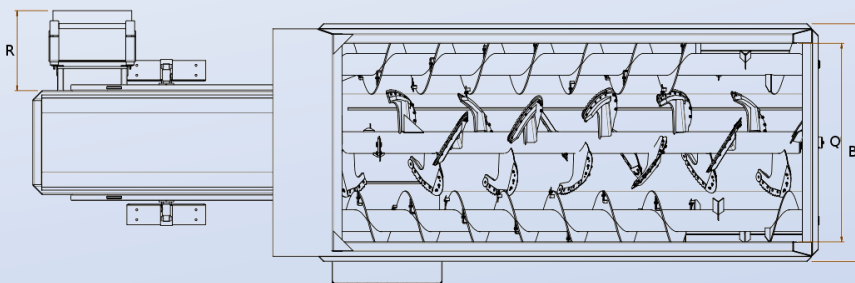
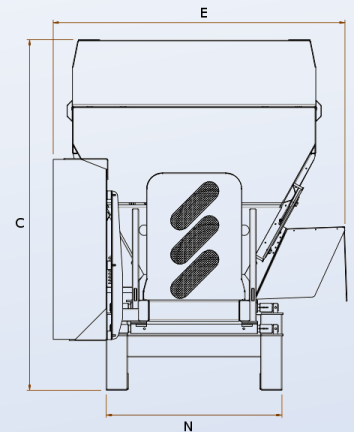
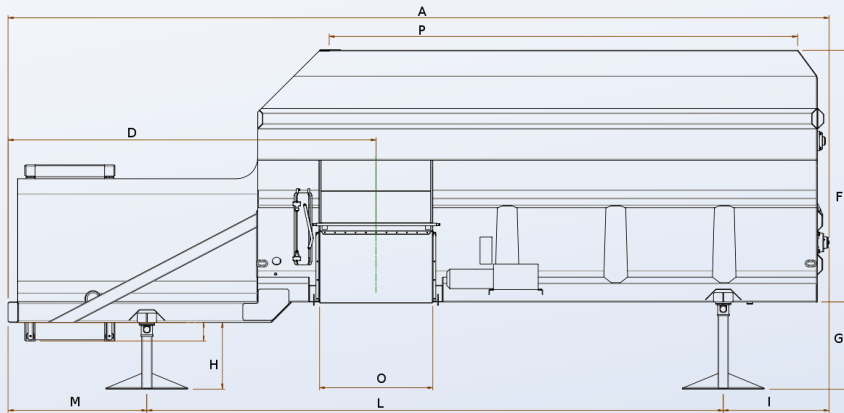

| MIX-ON | A | B | C | D | E | F | G | H |
|---------------|------|------|------|------|------|------|-----|-----|
| 159 E | 6710 | 2200 | 3000 | 3250 | 2540 | 2150 | 850 | 650 |
| 189 E | 7210 | 2200 | 3000 | 3500 | 2540 | 2150 | 850 | 650 |
| 2111 E | 8040 | 2410 | 3310 | 3600 | 2760 | 2460 | 850 | 650 |
| 2411 E | 8540 | 2410 | 3310 | 3600 | 2760 | 2460 | 850 | 650 |

| MIX-ON | I | L | M | N | O | P | Q | R |
|---------------|------|------|------|------|------|------|------|-----|
| 159 E | 1230 | 4000 | 1480 | 1520 | 1100 | 3800 | 1800 | 808 |
| 189 E | 1230 | 4500 | 1480 | 1520 | 1100 | 4300 | 1800 | 808 |
| 2111 E | 1050 | 5630 | 1360 | 1660 | 1100 | 4570 | 2010 | 808 |
| 2411 E | 1050 | 6130 | 1360 | 1660 | 1100 | 5070 | 2010 | 808 |