

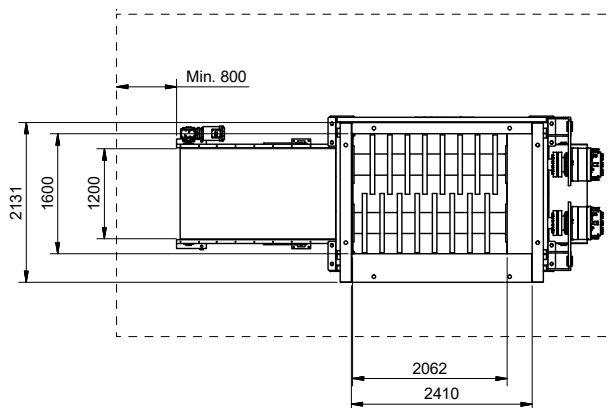

Waste Pre-Shredders from Metso Waste Recycling
M&J K210-2HS pre shredder

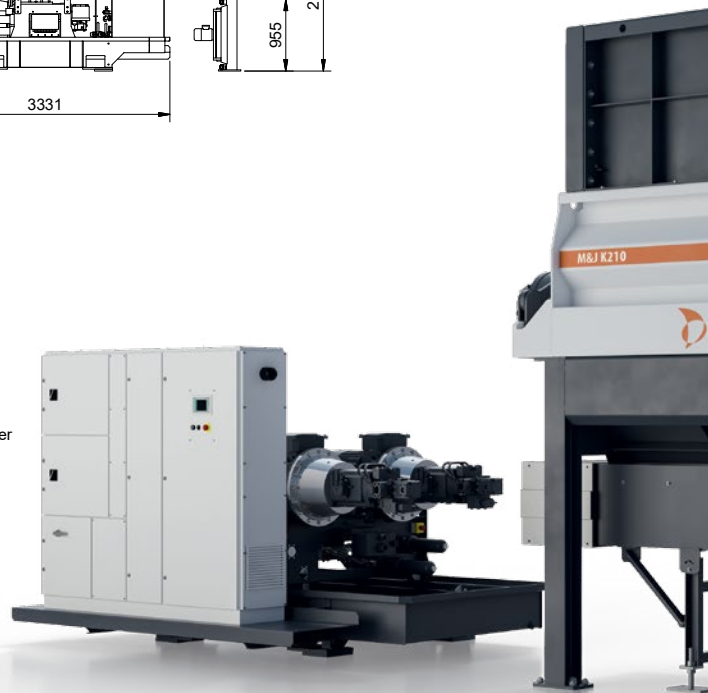

M&J K210-2HS pre shredder

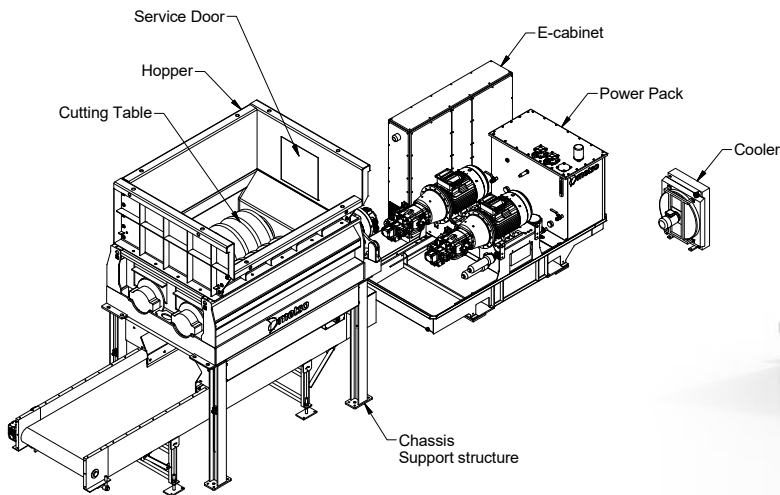
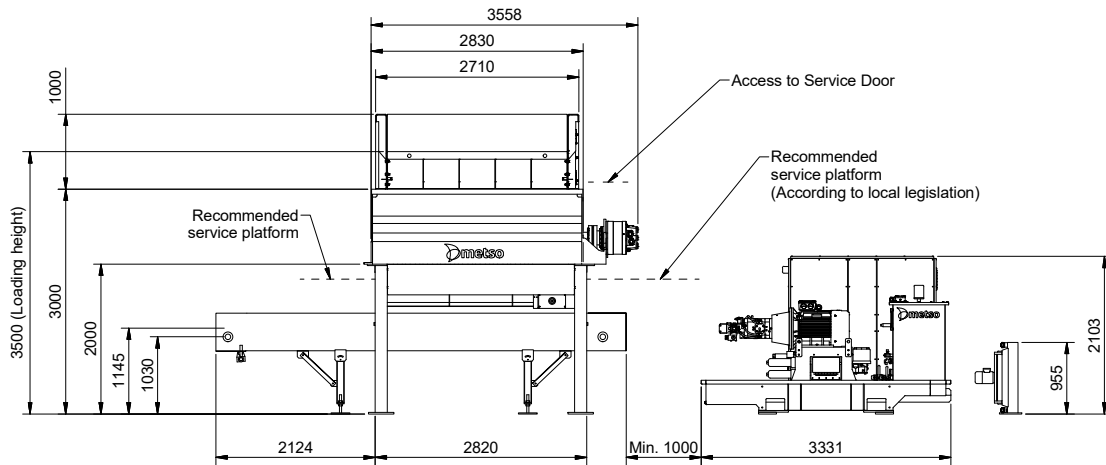

Specification

Overall dimensions shredder with standard hopper (LxWxH)	mm	5682 x 2131 x 4500
Weight (total included standard conveyor)	ton	10.5 - 11.4
Standard colour	RAL	7011, 9002
Loading height with standard hopper	mm	3500
Cutting area	mm	2062 x 1600

Power pack

Electric motor	kW	2x75 / 2x110 / 2x132
Electric control unit		PLC
Drive principle		Double hydrostatic transmission

Chassis

Standard belt conveyor (LxW)	mm	5000 x 1200
Discharge height	mm	1030
Discharge width	mm	1200
Weight (included / exclusive conveyor)	ton	2.0 / 1.1

Cutting table



Cutting table 7 knives



Cutting table 11 knives



Classic



Samurai



Tachi



Tomahawk



Butterfly



Dragon sword

Cutting Table		
Number of shafts		2
Rotating speed (Standard / High torque / High speed, High torque)	rpm	Up to 41 / 62 / 51
Number of knives		7 / 8 / 9 / 11
Number of counter knives		14 / 16 / 18 / 22
Cutting area (LxW)	mm	2062 x 1600
Weight complete cutting table	ton	7.7 - 8.7
Grain size		
7 knives	mm	90% less than 400
8 knives	mm	90% less than 300
9 knives	mm	90% less than 200
11 knives	mm	90% less than 125
Capacity per hour*		
Household waste	ton	Up to 45
Demolition wood	ton	Up to 40
Industrial waste	ton	Up to 20
Bulky waste	ton	Up to 25

* Depending on loading, grain size and density of the input material



For more information, contact your local Metso Waste Recycling representative, or contact your dealer directly.

www.metso.com/waste

Metso Waste Recycling

Vejlevej 5 Tel: +45 7626 6400
DK-8700 Horsens recycling.info.dk@metso.com

The information in this document is provided for guidance only and as is without warranty of any kind, either express or implied, including but not limited to the implied warranties of merchantability, fitness for a particular purpose or non-infringement. Information in this document may include information not appropriate to specific configurations, or information which has not been updated. Metso has the right to make changes in the document without notice. Not all products or services are available in all countries. In no event shall Metso be liable for any damages.

We reserve the right to make changes and improvements without notice, "M&J K210-2HS pre shredder". Metso Waste Recycling, April 2019, (E000669-0005)